



Series
MPX

SIZE 8 CONCENTRIC TWINAX PIN CONTACT NONENVIRONMENTAL
FOR EN 3375-003 CABLE AND MIL C 17/17600002 CABLE

Issue:
05 JUNE 01

Page
1 / 1

OUTER AND INTERMEDIATE CONTACT SUB-ASSEMBLY

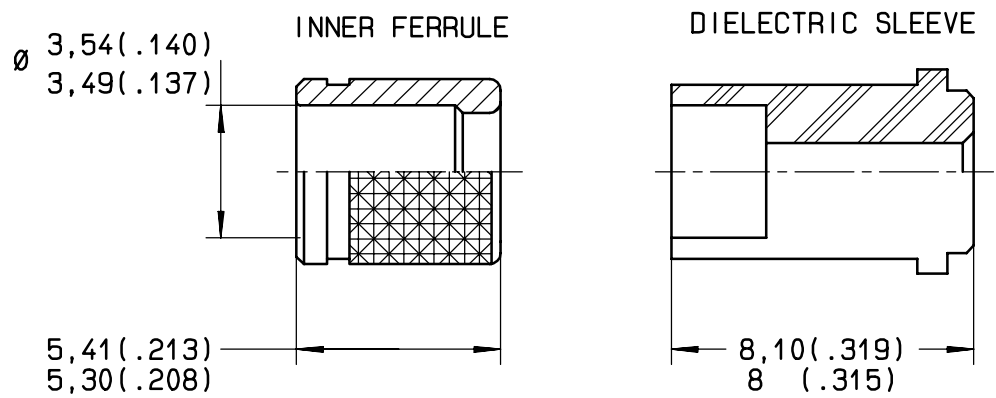
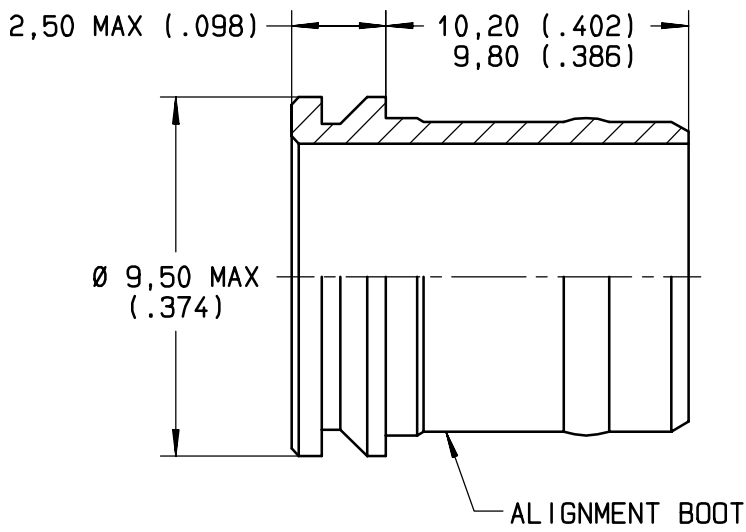
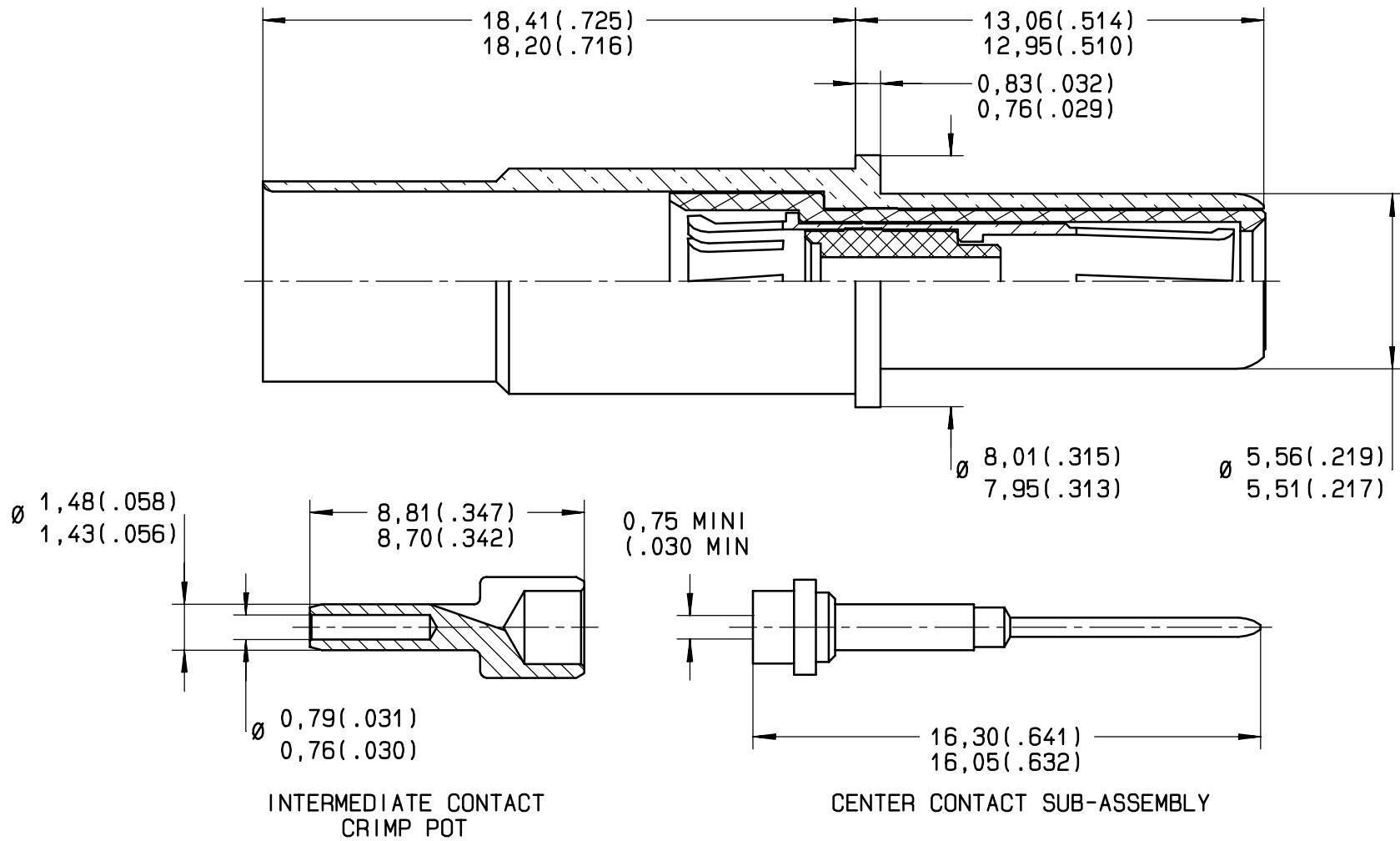

MATERIALS:

OUTER CONTACT: BERYLLIUM COPPER ALLOY PER ASTM-B-196 -ANNEALED ON CRIMP BARREL
 INTERMEDIATE CONTACT: BERYLLIUM COPPER ALLOY PER ASTM-B-196 HEAT TREATED
 CENTER CONTACT AND INTERMEDIATE CONTACT CRIMP POT : LEADED NICKEL COPPER (C97)
 INNER FERRULE: BRASS PER QQ-B-626
 DIELECTRIC PARTS DIELECTRIC SLEEVE AND ALIGNMENT BOOT: TPFE PER ASTM-D-1710 OR EQUIVALENT

FINISHES (ALL METAL PARTS)

GOLD PLATE PER MIL-G-45204, TYPE I OR II, GRADE C OR D, CLASS 1 50 MICROINCHES OVER NICKEL PLATE PER QQ-N-290, CLASS 2

SEE WIRING INSTRUCTIONS: RP3364

This information is given as an indication. In the continual goal to improve our products, we reserve the right to make any modifications judged necessary.

4112-9610

CREATION
PEN: /
NOM: MARIE
DATE: 07 SEP 1987	05 JUNE 01	CABLE MIL C 17/17600002 WAS MIL C 17/176000002	MACARI	.
APPR.: .	12 MAR 01	REDRAWN	VALGRESY	MACARI
	Issue	Revisions	Name	Approved

RADIALL[®]

101, rue Philibert Hoffmann Z.I. Ouest
 93116 ROSNY/BOIS Cedex (France)
 Tl.: 01 49 35 35 35
 Fax.: 01 48 54 63 63
 Tlax: RADIA 235220